



گروه فنی مهندسی جوش و برش مقدم

اعتماد از شما کیفیت و تخصص از ما



09153223758



051-37581400



<https://www.moghadamwelding>



<http://instagram.com/moghadam>



<https://t.me/moghadamwelding>



<https://whatsapp.com/channel>



<https://rubika.ir/moghadamwelding>



مشهد خیام شمالی 63 خیابان پردیس 3

برای کسب اطلاعات بیشتر بر روی لینک ها کلیک کنید

- 7 سال سابقه آموزش تعمیرات تخصصی دستگاه های جوش اینورتری تک فاز و 3 فاز
- 7 سال سابقه فروش قطعات الکترونیکی دستگاه جوش تک فاز و 3 فاز
- آموزش تخصصی تحلیل دستگاه های جوش اینورتری مختص ابراز فروشان
- آموزش تخصصی ابراز آلات شارژی

Vishay BCcomponents

Ceramic Disc Capacitors

Class 2, low loss 500 V, 1 kV, 2 kV and 3 kV

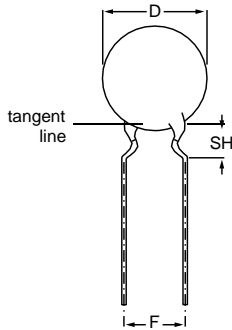

Capacitors with inside kink lead spacing

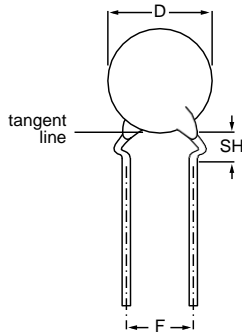

Capacitors with outside kink lead spacing

FEATURES

- High reliability
- Low losses
- High capacitance in small size
- Kinked leads
- Lead (Pb)-free available



RoHS COMPLIANT

APPLICATIONS

In electronic circuits where low losses and high capacitance per volume are essential, for example:

- SMPS
- HF ballast
- Snubber and high voltage circuits

DESIGN

The capacitors consist of a ceramic disc both sides of which are silver-plated. Connection leads are made of tinned copper having a diameter of 0.6 mm or 0.8 mm.

The capacitors are supplied with kinked leads and lead spacings of 5 mm or 7.5 mm and 10 mm. Encapsulation is made of epoxy-resin, flammable resistant in accordance with "UL94V-0".

CAPACITANCE RANGE

100 to 4700 pF

RATED DC VOLTAGE

500 V; 1 kV; 2 kV; 3 kV

DIELECTRIC STRENGTH

200 % of rated voltage

INSULATION RESISTANCE AT 500 V (DC)

≥ 10 000 MΩ min

TOLERANCE ON CAPACITANCE

± 10 %; ± 20 %

DISSIPATION FACTOR

0.2 % Max

OPERATING TEMPERATURE RANGE

- 30 to + 125 °C

TEMPERATURE COEFFICIENT Y5R (2C4) - 30 TO + 85 °C:

± 15 %

SECTIONAL SPECIFICATIONS

IEC 60384-9, EIA 198

AGEING

Typical 0.5 % per time decade

MARKING

Marking indicates capacitance value and tolerance in accordance with "EIA 198" and voltage marks.

Examples of marking code

Disc size (D_{max}) ≤ 6.5 mm:

RR = low loss with T.C.

Y5R

101 k

2 kV

Disc size (D_{max}) ≥ 7.5 mm:

BC

RR

102 k

3 kV

The capacitors meet the essential requirements of "IEC 60384-9 and EIA 198". Unless stated otherwise all electrical values apply at an ambient temperature of 25 ± 3 °C, at normal atmospheric conditions



Ceramic Disc Capacitors
Class 2, low loss 500 V, 1 kV, 2 kV and 3 kV

Vishay BCcomponents

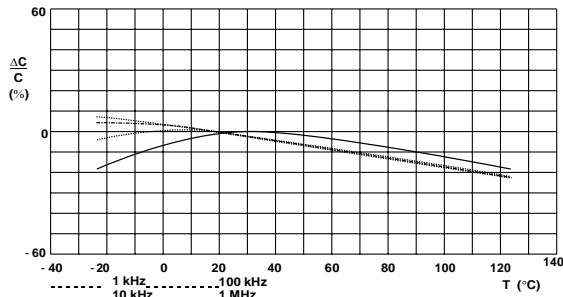

Typical capacitance change as a function of temperature and frequency

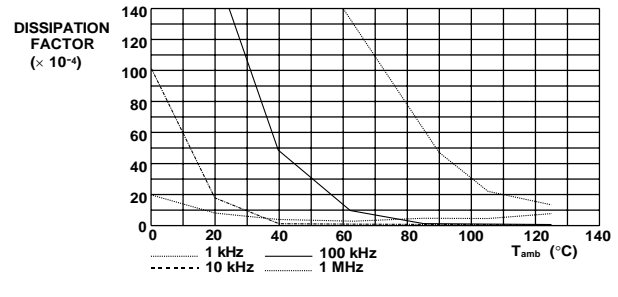

Typical dissipation factor as a function of temperature and frequency

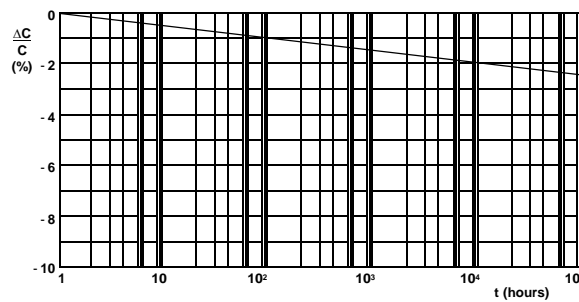

Ageing rate as a function of time

ORDERING INFORMATION

C (pF)	TOL. (%)	D _{max} (mm)	LEAD SPACING S (mm)	SH ⁽²⁾ (mm)	CLEAR TEXT CODE
					13 th DIGIT: T = REEL; U = AMMO; 3 = BULK 16 th DIGIT: R = RoHS COMPLIANT
500 V					
100	± 10	5.0	5.0	4.0	F101K20Y5RL6.J5.
120					F121K20Y5RL6.J5.
150					F151K20Y5RL6.J5.
180					F181K20Y5RL6.J5.
220					F221K20Y5RL6.J5.
270					F271K20Y5RL6.J5.
330					F331K20Y5RL6.J5.
390					F391K25Y5RL6.J5.
470					F471K25Y5RL6.J5.
560					F561K25Y5RL6.J5.
680		F681K25Y5RL6.J5.			
820		F821K29Y5RL6.J5.			
1000		F102K29Y5RL6.J5.			
1200		F122K33Y5RL6.J5.			
1500		F152K33Y5RL6.J5.			
1800		F182K39Y5RL6.J5.			
2200		F222K39Y5RL6.J5.			
2700		F272K47Y5RL63J7.			
3300		F332K53Y5RL63J7.			
3900		F392K53Y5RL63J7.			
4700	F472K53Y5RL63J7.				



ORDERING INFORMATION					
C (pF)	TOL. (%)	D _{max} (mm)	LEAD SPACING S (mm)	SH ⁽²⁾ (mm)	CLEAR TEXT CODE
					13 th DIGIT: T = REEL; U = AMMO; 3 = BULK 16 th DIGIT: R = RoHS COMPLIANT
1 kV					
100	± 10	6.5	5.0	4.0	F101K25Y5RN6.J5.
120					F121K25Y5RN6.J5.
150					F151K25Y5RN6.J5.
180					F181K25Y5RN6.J5.
220					F221K25Y5RN6.J5.
270					F271K29Y5RN6.J5.
330		F331K29Y5RN6.J5.			
390		F391K29Y5RN6.J5.			
470		F471K29Y5RN6.J5.			
560		F561K33Y5RN6.J5.			
680		F681K33Y5RN6.J5.			
820		F821K39Y5RN6.J5.			
1000		F102K39Y5RN6.J5.			
1200		F122K43Y5RN6.J5.			
1500		F152K43Y5RN6.J5.			
1800		F182K47Y5RN63J7.			
2200		F222K53Y5RN63J7.			
2700		F272K53Y5RN63J7.			
3300		F332K69Y5RN63J7.			
3900		F392K69Y5RN63J7.			
4700	F472K75Y5RN83J0.				
2 kV					
100	± 10	6.5	5.0	4.0	F101K25Y5RP6.K5.
120					F121K25Y5RP6.K5.
150					F151K25Y5RP6.K5.
180					F181K29Y5RP6.K5.
220					F221K29Y5RP6.K5.
270					F271K29Y5RP6.K5.
330		F331K29Y5RP6.K5.			
390		F391K33Y5RP6.K5.			
470		F471K33Y5RP6.K5.			
560		F561K39Y5RP6.K5.			
680		F681K39Y5RP6.K5.			
820		F821K43Y5RP6.K5.			
1000		F102K43Y5RP6.K5.			
1200		F122K47Y5RP63K7.			
1500		F152K53Y5RP63K7.			
1800		F182K53Y5RP63K7.			
2200		F222K69Y5RP63K7.			
2700		F272K75Y5RP83K0.			
3300		F332K75Y5RP83K0.			
3900		F392K75Y5RP83K0.			
4700	F472K96Y5RP83K0.				



Ceramic Disc Capacitors
Class 2, low loss 500 V, 1 kV, 2 kV and 3 kV

Vishay BCcomponents

ORDERING INFORMATION					
C (pF)	TOL. (%)	D _{max} (mm)	LEAD SPACING S (mm)	SH ⁽²⁾ (mm)	CLEAR TEXT CODE
					13 th DIGIT: T = REEL; U = AMMO; 3 = BULK 16 th DIGIT: R = RoHS COMPLIANT
3 kV					
100	± 10	8.5	7.5	4.0	F101K33Y5RR6.K7.
120					F121K33Y5RR6.K7.
150					F151K33Y5RR6.K7.
180					F181K33Y5RR6.K7.
220					F221K33Y5RR6.K7.
270					F271K33Y5RR6.K7.
330					F331K33Y5RR6.K7.
390					F391K39Y5RR6.K7.
470					F471K39Y5RR6.K7.
560					F561K43Y5RR6.K7.
680					F681K43Y5RR6.K7.
820					F821K53Y5RR63K7.
1000					F102K53Y5RR63K7.
1200					F122K59Y5RR63K7.
1500		F152K59Y5RR63K7.			
1800		F182K75Y5RR83K0.			
2200		F222K75Y5RR83K0.			
2700		F272K84Y5RR83K0.			

Notes

- Maximum thickness: 500 V = 3.5 mm; 1 kV = 4.5 mm; 2 kV = 5.0 mm; 3 kV = 6.0 mm.
- SH = seated height.

PACKAGING					
PACKAGING TYPE	SIZE CODE	LEAD SPACE (mm)	VOLTAGE (VDC)	SPQ	BOX DIMENSIONS L X W X H (mm)
Bulk (long lead L ≥ 25.4 mm)	20 to 25	all	all	1000	245 x 120 x 65
	29 to 39			1000	
	43 to 47			1000	
	53 to 75			500	
	84 to 96			250	
Tape and reel	≤ 47	≤ 6.4	< 500	2500	370 x 370 x 60
			500 ≤ WV ≤ 2000	2000	
			3000	1000	
	≥ 7.5	all	1000		
≥ 53	all	all	1000		
Ammopack	≤ 47	≤ 6.4	< 500	2000	335 x 240 x 50
			500 ≤ WV < 2000	2000	335 x 290 x 50
			2000 and 3000	1500	
	≥ 7.5	all	1500	360 x 330 x 55	
	≥ 53	all	all	1500	335 x 290 x 50

Note

The capacitors are supplied in bulk packaging (cardboard boxes), in tape on reel or in ammpack

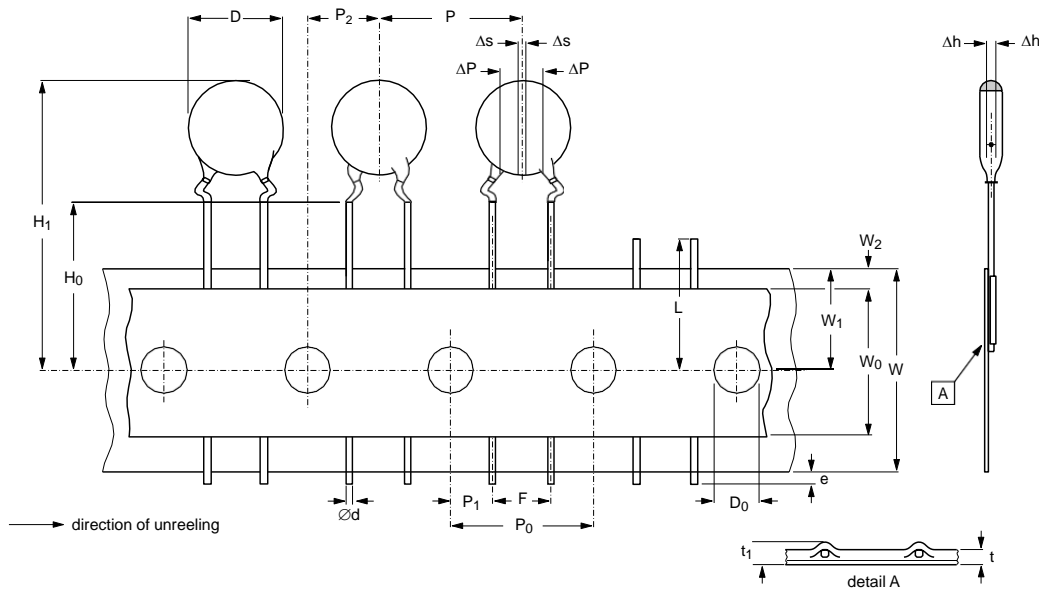

Capacitors, lead spacing 5.0 mm or 7.5 mm, on tape

Kinked capacitors on tape, lead spacing 5.0 mm (0.2 inch) or 7.5 mm (0.3 inch)

DIMENSIONS OF TAPE		DIMENSIONS (mm)	
SYMBOL	PARAMETER	FEED-HOLE PITCH $P_0 = 12.7$	FEED-HOLE PITCH $P_0 = 15.0$
		D	body diameter
d	lead diameter	0.6 ± 0.05	0.6 ± 0.05
P	pitch between capacitors	12.7 ± 1.0	15.0 ± 1.0
P_0	feed-hole pitch	12.7 ± 0.3 ; note 1	15.0 ± 0.3 ; note 1
ΔP	plane deviation	1.0 max.	1.0 max.
P_1	feed-hole centre to lead centre	3.85 ± 0.7 ; note 2	3.75 ± 1.0 ; note 2
P_2	feed-hole centre to component centre	6.35 ± 1.3 ; note 2	7.5 ± 1.5 ; note 2
F	lead spacing	$5.0 + 0.6/- 0.4$	7.5 ± 1.0
Δh	component alignment	0 ± 1.0	0 ± 1.0
ΔS	deviation along tape, left or right	0 ± 1.0	0 ± 1.0
W	tape width	$18.0 + 1.0/- 0.5$	$18.0 + 1.0/- 0.5$
W_0	hold-down tape width	5.0 min.	5.0 min.
W_1	hole position	$9.0 + 0.75/- 0.5$	$9.0 + 0.75/- 0.5$
W_2	hold-down tape margin	3.0 max.	3.0 max.
H_0	height to seating plane	16.0 ± 0.5	16.0 ± 0.5
H_1	maximum component height	32.0	40.0
e	lead end protrusion	1.0 max.	1.0 max.
L	maximum length of snapped lead	11.0	11.0
D_0	feed-hole diameter	4.0 ± 0.2	4.0 ± 0.2
t	total tape thickness	0.9 max.	0.9 max.
t_1	maximum thickness of tape and wires	1.5 max.	1.5 max.

Notes

1. Cumulative pitch error: $\pm \leq 1$ mm/20 pitches.
2. Obliquity maximum 3°



REEL AND TAPE DATA in millimeters

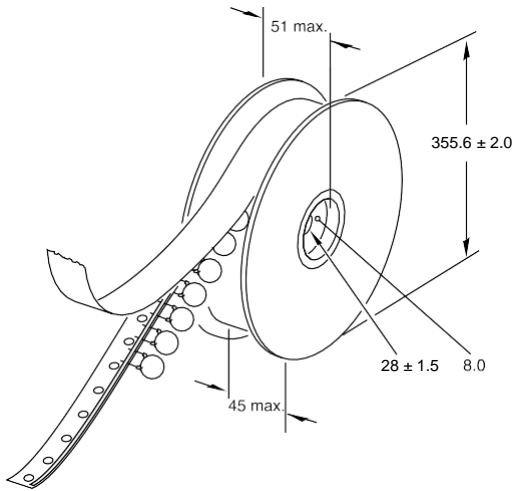

Reel with capacitors on tape

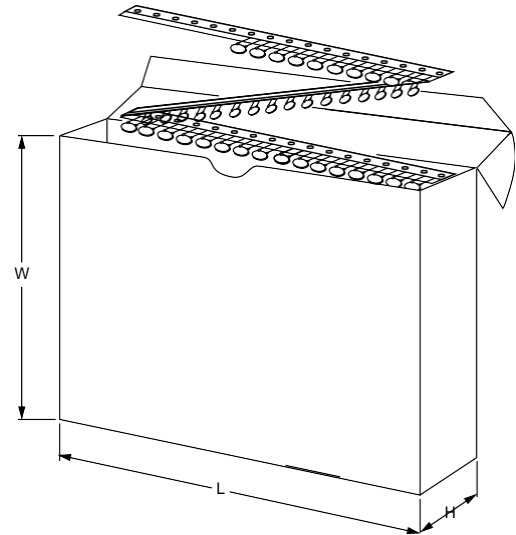

Ampmopack with capacitors on tape

DIMENSIONS OF AMMOPACK			
PARAMETER	DISC SIZE (D_{max})		UNIT
	6.5 to 11.0 mm	12.0 to 13.5 mm	
Taping pitch	12.7	15.0	mm
L	335	360	mm
W	290	330	mm
H	50	55	mm



Notice

Specifications of the products displayed herein are subject to change without notice. Vishay Intertechnology, Inc., or anyone on its behalf, assumes no responsibility or liability for any errors or inaccuracies.

Information contained herein is intended to provide a product description only. No license, express or implied, by estoppel or otherwise, to any intellectual property rights is granted by this document. Except as provided in Vishay's terms and conditions of sale for such products, Vishay assumes no liability whatsoever, and disclaims any express or implied warranty, relating to sale and/or use of Vishay products including liability or warranties relating to fitness for a particular purpose, merchantability, or infringement of any patent, copyright, or other intellectual property right.

The products shown herein are not designed for use in medical, life-saving, or life-sustaining applications. Customers using or selling these products for use in such applications do so at their own risk and agree to fully indemnify Vishay for any damages resulting from such improper use or sale.